

## 50 SERIES LEVEL SWITCHES

One-float level switch for external side mounting, with one switching unit. For pressure up to 50 Bar max., temperatures between -10°C and 135°C for fluids with specific gravity of 0.85 kg/dm<sup>3</sup> min. (1.0 kg/dm<sup>3</sup> for the 56 model). Fixed differential, with SP.GR. 1 kg/dm<sup>3</sup>, 30 mm. This means that the change-over takes place by increased (or decreased) contact level, the following change-over will take place when the level falls (or rises) by 30 mm. Set point accuracy ±5 mm.

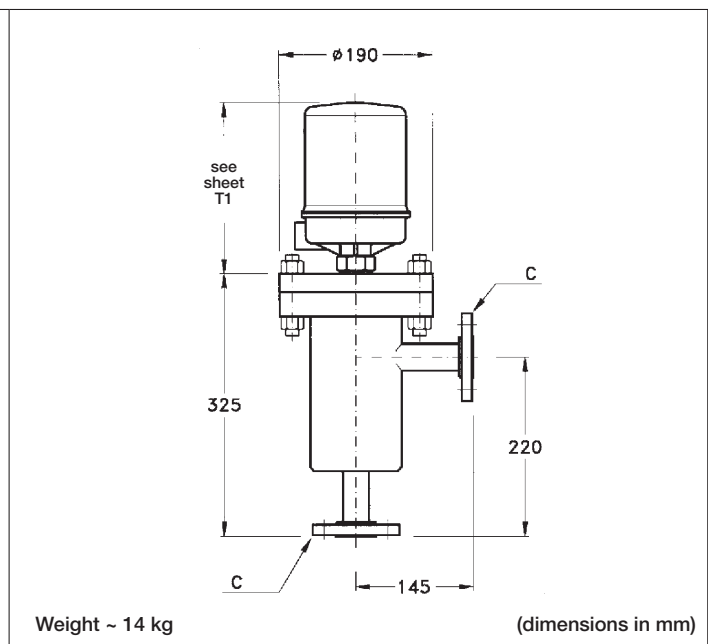
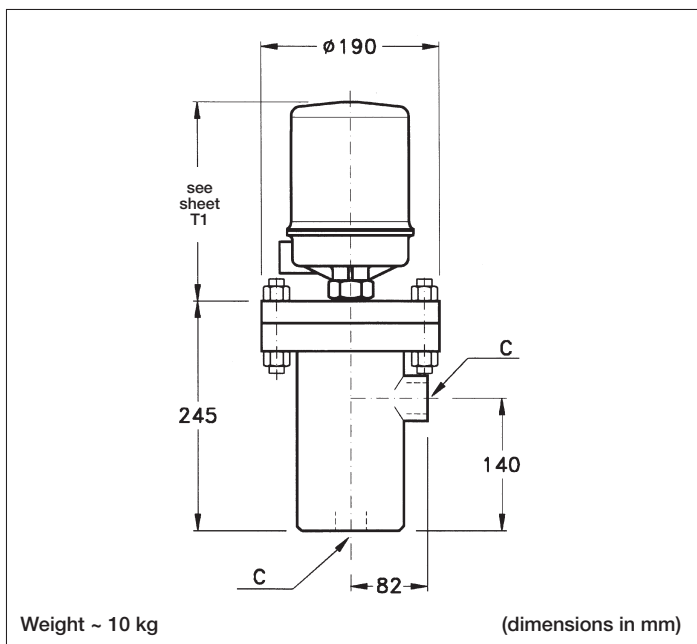
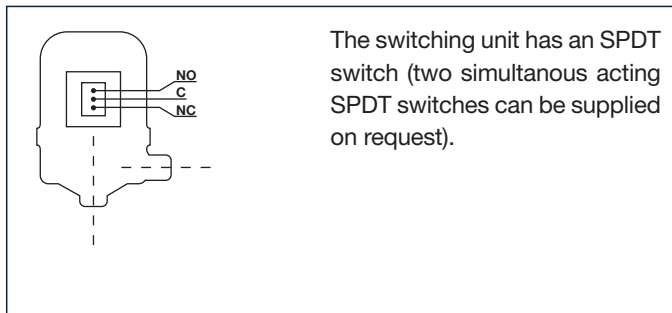

**NOTE.** The set points are supplied on request, since these change according to specific gravity and working conditions.

Standard “C” connectors: Threading 1” NPT-F; Flange UNI PN ....DN 25/1” ANSI.....RF; 1” S.W.  
On request, non-standard threads and flanges can be supplied.

On request, special versions can be supplied for working at temperatures below -10°C and over 135°C.

## WORKING CONDITIONS

MODEL		52			56		
STD "C" FLANGE		1" ANSI 150 RF UNI DN 25 PN 16			1" ANSI 600 RF UNI DN 25 PN 64		
VERSION		A	I	J	A	I	J
Temperatures	38° C	20	19	19	52	50	50
	100° C	17	15	16	46	40	42
	135° C	16	14	15	46	37	39
	BODY RATING	ANSI 150			ANSI 300		

Max pressure in bar

## MATERIALS

CODE FOR:	Materials	Carbon steel	AISI 304	AISI 316
	Body	A	I	J
	Float	-	-	2

## SWITCHES

Type	Mercury switch	Dry microswitch					Pneumatic switch*
Load rating	220 V a. c. 10 A 110 V d. c. 1,5 A	250 V a. c. 10 A 125 V d. c. 0,5 A	125 V d. c. 10 A	250 V a. c. 10 A 125 V d. c. 0,5 A waterproof	125 V a. c. 1 A 28 V d. c. 1 A waterproof with gold contacts	250 V a. c. 1A 24 V d.c. 3A sealed with inert gas	Output: 0 ÷ 40 psi max.
CODE	VD	M2	M3	M4	M6	M14	PNA (aluminium)

\*Air inlet and output connection 1/4" NPT-F - No bleed type

## ENCLOSURES

Type	Waterproof	Explosion-proof	The (WP) enclosures can be supplied whit gland or with a 3 or 7 pole connector as per MIL standards.  The (EP) enclosures can be supplied whit explosion-proof gland.  1) CESI certificate N. 02-ATEX-126
Material	Aluminium	Aluminium	
Electrical Connection	1/2" NPT-F/GAS 3/4" NPT-F/GAS ISO M20X1.5	1/2" UNI 6125/NPT-F 3/4" UNI 6125/NPT-F ISO M20X1.5	
Protection degree	IP 66	ATEX II 2 G Ex d IIC T6 o T5 Gb ATEX II 1/2 D Ex ta/tb IIIC T85° o T100° C Da/Db IP 66	
CODE	WP	EP	

## HOW TO ORDER

Example: 52 - A - 2 - M2 - WP

52	model
A	body in carbon steel
2	float in S/steel AISI 316
M2	dry microswitch 250 V a.c. - 10 A
WP	waterproof enclosure

The following data are required: type of fluid, specific gravity, operating temperature and pressure.