

VISUAL FLOW INDICATORS - IVF SERIES

SLE - SCE - SBE MODELS

Free passage visual flow indicator for horizontal and vertical mounting. For pressure up max. 25 Bar and temperature up to max. 130°C. On request, versions for higher pressures and temperatures can be made.

Flow indicators are devices for the visual confirmation that a fluid is flowing through the pipelines.

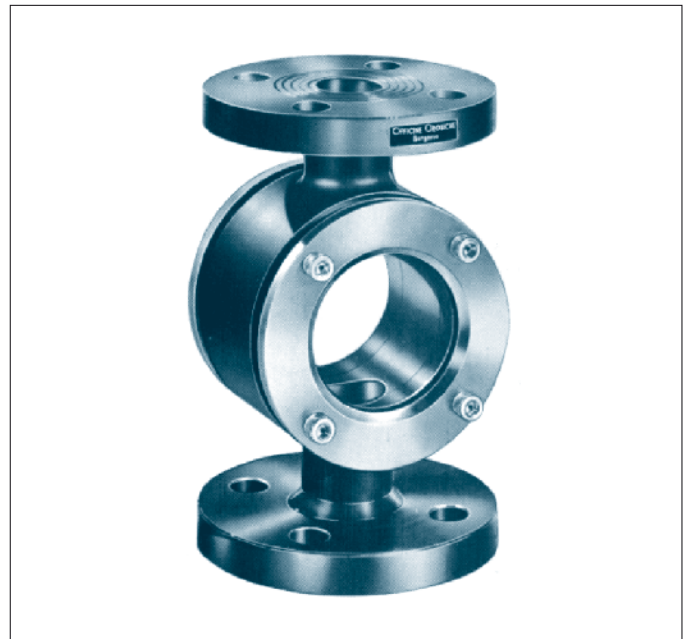

IVF/SLE MODEL:

Free passage visual flow indicator for horizontal and vertical mounting. Made in metallic and plastic materials.

The plastic type is available up to mode SLE 80 and for operating pressures as per the table "TOLERANCE LIMITS OF THE PLASTIC TYPE VISUAL INDICATORS".

FLANGED

Standard "C" flange UNI PN 16 - ANSI 150 RF
On request, other types of flanges can be made.

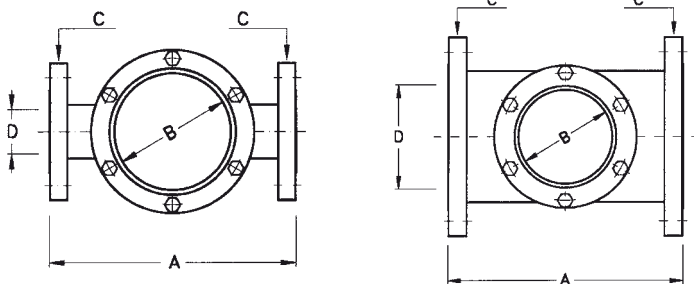

from DN 15 to DN 80

from DN 100 to DN 200

MOD.	A mm	B mm	D		WEIGHT ⁽¹⁾ IN ~ kg
			UNI	ANSI	
SLE 15	180	47	15	1/2"	2,5
SLE 20	180	47	20	3/4"	3
SLE 25	180	47	25	1"	3,5
SLE 32	180	47	32	1 1/4"	5
SLE 40	240	80	40	1 1/2"	8
SLE 50	240	80	50	2"	9
SLE 65	280	90	65	2 1/2"	15
SLE 80	290	90	80	3"	16,5
SLE 100	250	78	100	4"	18,5
SLE 125 ⁽²⁾	300	120	125	5"	24
SLE 150 ⁽²⁾	300	120	150	6"	25,5
SLE 200 ⁽³⁾	350	140	200	8"	32

1) Refers to metallic type. - 2) Max. operating pressure 10 Bar.
3) Max. operating pressure 9 Bar.

THREADED

Standard "C" threaded connections GAS/NPT-F and socket welding.

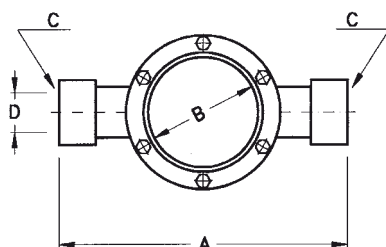

MOD.	A mm	B mm	D	WEIGHT ⁽¹⁾ in ~ kg
SLE 15	210	47	1/2"	1,5
SLE 20	210	47	3/4"	2
SLE 25	220	47	1"	2,5
SLE 32	230	47	1 1/4"	3,5
SLE 40	300	80	1 1/2"	6
SLE 50	300	80	2"	7
SLE 65	350	90	2 1/2"	11
SLE 80	360	90	3"	12,5

1) Refers to metallic type.

IVF/SCE MODEL:

Visual flow indicator with chain to further improve the visibility of flow. Sizes are the same as for the IVF/SLE model. This model is not made in plastic materials.

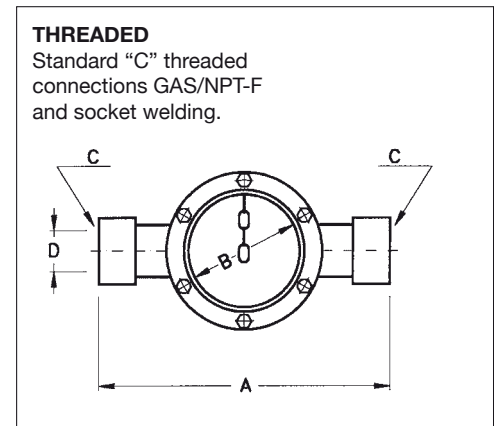
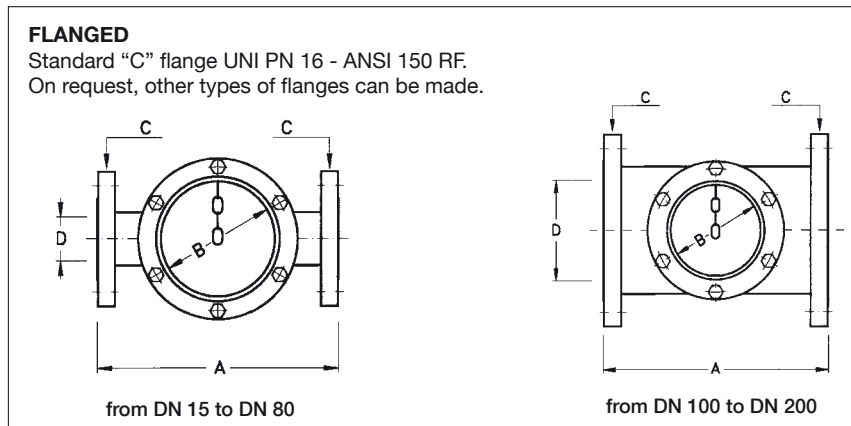

IVF/SBE MODEL:

Visual flow indicator with fixed paddle to create vortex in the passage of the fluid and improve the visibility of flow. Sizes are the same as for the IVF/SLE model.

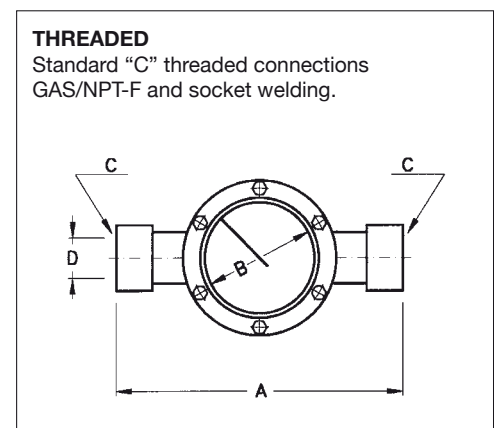
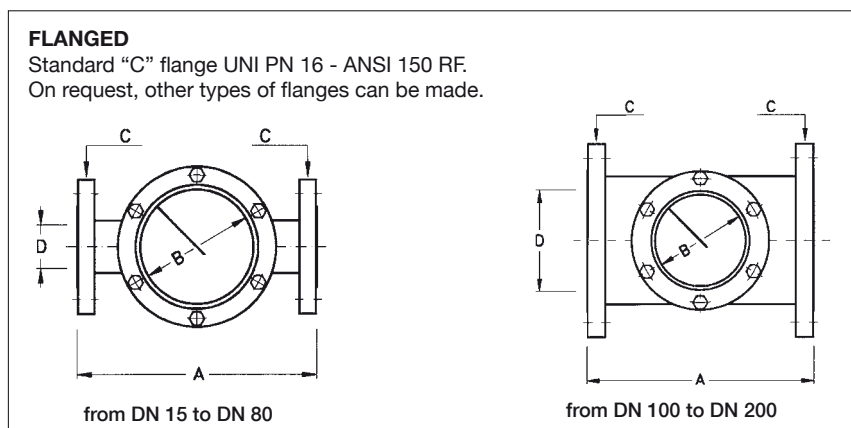

MATERIALS

CODE FOR:	Materials	Carbon steel	AISI 304	AISI 316	PVC	Moplen
	Body	A (1)	I (1)	J (1)	P (2)	M (2)
Paddle or chain	-	-	2	5	6	
(1) Internal gaskets		Asbestos free (A)	Neoprene (N)	Teflon (T)	Viton (V)	- (2) Internal gaskets Neoprene (N) Viton (V)

The flanges of the glasses and the screws can be supplied in galvanized steel or AISI 304.

TOLERANCE LIMITS OF THE PLASTIC TYPE VISUAL INDICATORS

MATERIALS	PVC	MOPLEN
	from 0° C to + 60° C pressure 6 bar at 25° C; 4 bar at 35° C; 1 bar at 60° C	from 0° C to + 80° C pressure 6 bar at 25° C; 4 bar at 45° C; 1 bar at 80° C

HOW TO ORDER

Example: IVF/SLE 50 - A - N

Example: IVF/SBE 50 - A - 2 - N

IVF/SLE IVF series, SLE model
50 Diameter of connections
A Body in carbon steel
N Neoprene Gaskets

IVF/SBE IVF series, SBE model
50 Diameter of connections
A Body in carbon steel
2 Paddle in S/steel AISI 316
N Neoprene gaskets

The following data is also required: type of fluid, , operating temperature and pressure.